

Tentazione

Design: Giorgio Soressi



Description

Structure frame with solid wood and multilayer wood, springing system with elastic webbing, padded with non-deformable polyurethane foam and covered with polyester fibre + velveteen. Base made of metal with bright chrome finish.







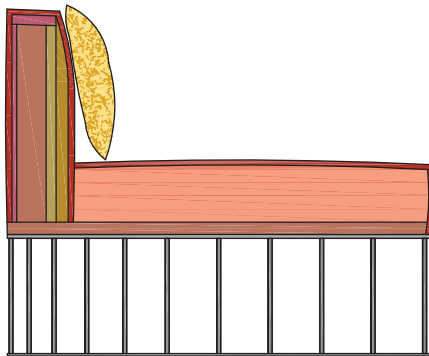

Seat in non-deformable polyurethane foam and covered with polyester fibre + velveteen.

Back cushion in Cotton fabric filled with natural goose feather.

Covers can be made with fabric or leather.

Composition



-   Natural goose feather
-  Polyurethane PF 30/SM (2,5 kPa)
-  P.F. 150 gr/m² + velveteen.
-  Polyurethane 40/EM (3,9 kPa)
-  Polyurethane 75/SR (14,0 kPa)
-  Polyurethane 40/PH (8,0 kPa)
-  Frame in solid and multilayer wood
-  Steel base with bright chrome finish

Tentazione

Dimensions

30"3/8W x 34"1/4D x 29"1/8H
SH: 16"1/8

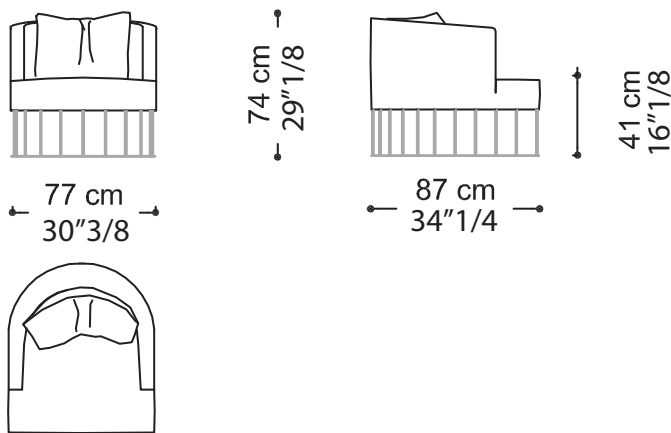

Finishes and materials

Covered in: Fabric (Cat. 1,2,3 and Super) or Leather (A,B,C and Extra).
Base in: Bright chrome finish. Additional cost for golden, satin bronze and black chrome finish.

(For more specifications, please refer to "Finishes & Materials")