

Pacific

Design: Daniele Lo Scalzo Moscheri

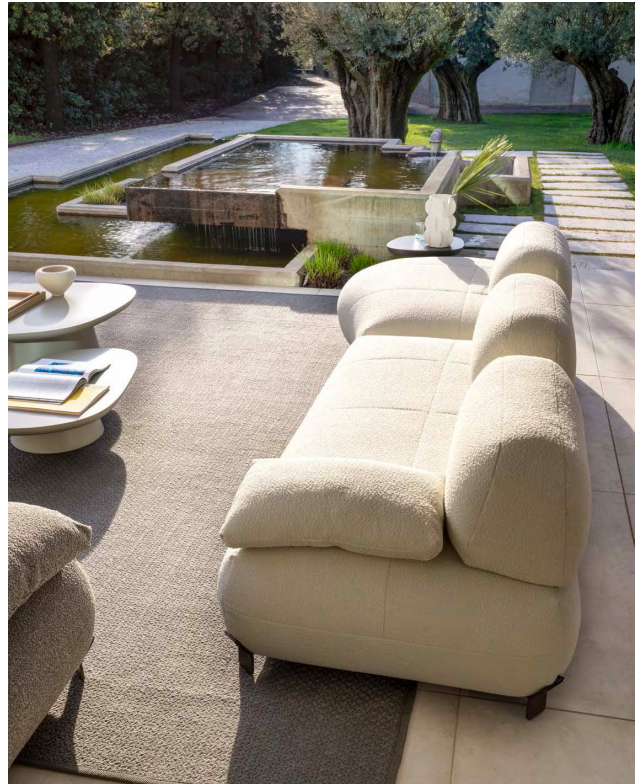

Description

Sectional inspired by the ocean waves. Its organic forms recall the fluidity of the waves, while its rounded details create islands of relaxation. This modular sofa, designed for outdoor use, can be complemented with a stylish armrest cushion and an elegant ottoman, perfect to create an innovative and contemporary outdoor space. Made in Italy.

Technical information:

Upholstering: Fabric for outdoor. Removable.

Structure: Solid wood bearing okume' blocks of various thicknesses and panels of multilayered okume'.

Suspension: Polyurethane foam backrest. Seat with pretensioned crossed propylene fiber.

Feet: 2"3/8H. Light brown (ME11).

Pacific

Dimensions

Composition A: 94"W x 46"7/8D x 29"1/2H

Composition B: 131"7/8W x 46"7/8D x 29"1/2H

Seat height: 17"3/8

Optional Ottoman:

37"3/4W x 37"3/4D x 29"1/2H

Optional Arm cushion:

13"W x 21"5/8D x 5"1/8H

Composition A

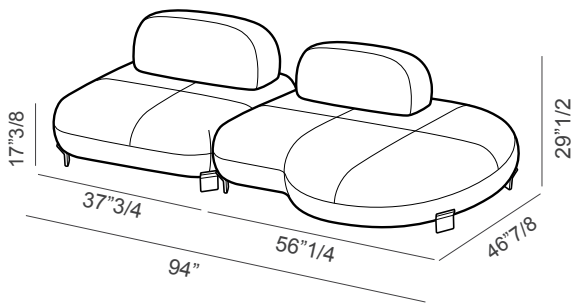

Composition B

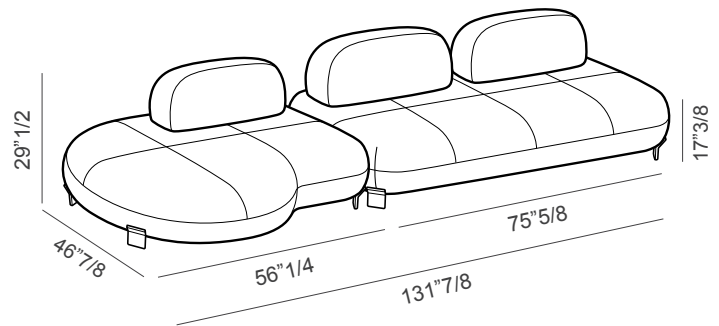

Optional ottoman

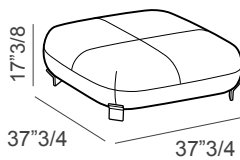

Optional arm cushion

