

NOHRD Eau-Me Board

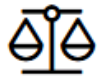

COMPACT
Only ø 64 cm



ACTIVATES
Balance & deep core muscles



WITH WATER
More challenge & benefits



QUIET
During use



DURABLE
High-quality materials

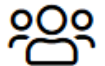

1 FOR ALL
Suits all fitness levels



Description

The Eau-Me Board is a new-generation balance board boasting a patented combination of classic balance training with the element of water. The Eau-Me Board is all about balance.

Designed to simulate uneven ground, your body is continuously engaged, while the board aims to tilt you off center. The water-filled base is sure to react against your every move – guaranteed to deliver an extra dimension to your balance & core stability session.

Definitely a surprisingly challenging addition to your wellness exercise routine. Suitable for all ages and, if used regularly, will enhance fitness and balance while always remaining easy on the joints- in the home, office, or studio.

Eau-Me Board

Dimensions

Ø25"1/4 x 6"5/8H

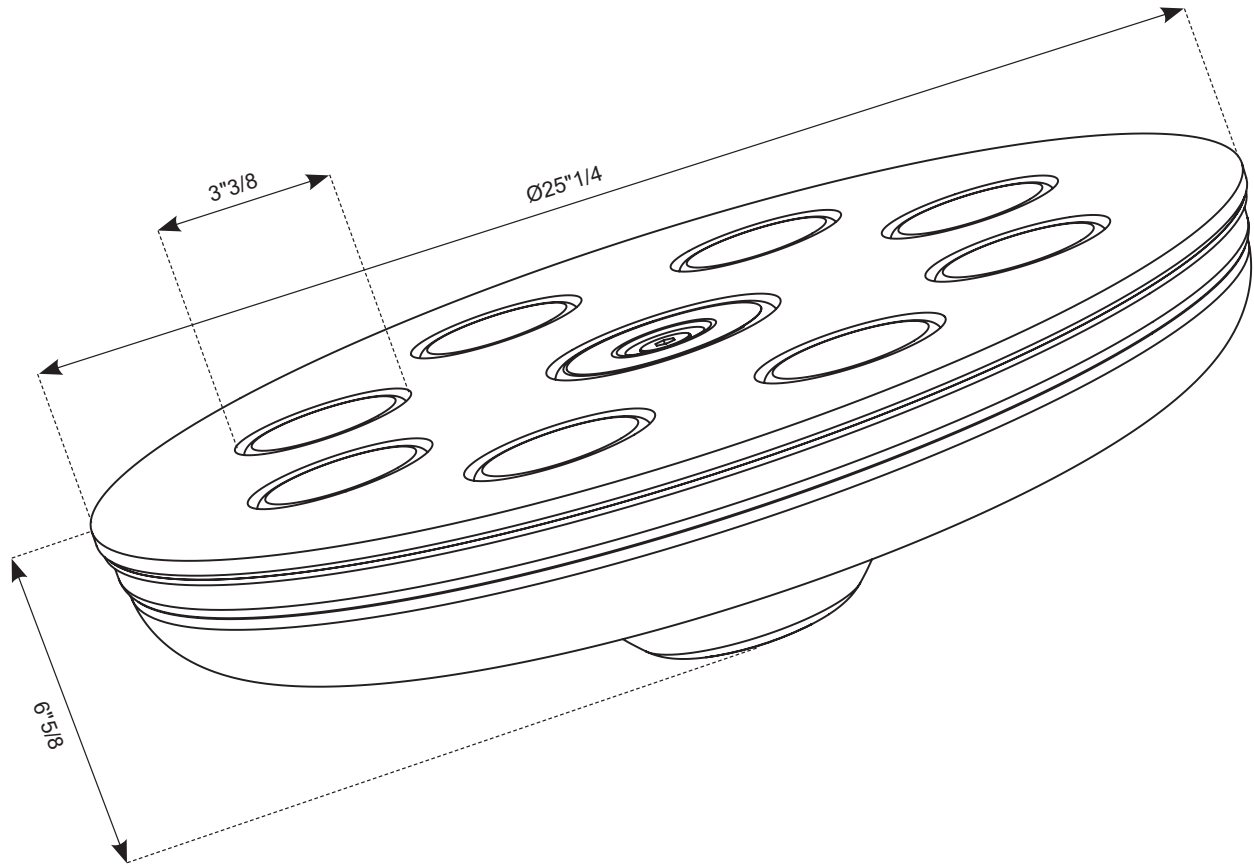

NOHRD Viva Ball



Description

A versatile solution for strength, coordination, and flexibility – the VivaBall is your ideal training partner, whether you're targeting deep muscle activation, improving balance, or enhancing mobility. Its sleek design integrates seamlessly into any home or gym setting while also benefiting your posture. The slightly unstable surface promotes active sitting, strengthening the back muscles and helping prevent tension and postural imbalances.

With the VivaBall, you can engage almost every muscle group. Whether for yoga, Pilates, functional training, or classic stretching exercise, this multi-use tool adapts to your workout needs.

Made from eco-friendly materials, the VivaBall offers a comfortable texture and versatile application for a seamless fitness experience.

Viva Ball

Dimensions

Ø29"1/2

